

**Roues à bandages caoutchouc standard
et jante tôle d'acier**
Roulettes Type GB / Type GBL / GBB

*Wheels with standard solid rubber tyres
and pressed steel rims*
Castors Type GB / Type GBL / GBB

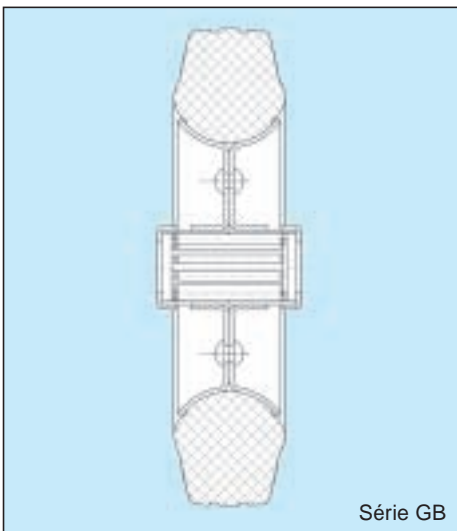

Série GB











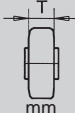

Série GB

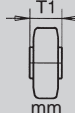







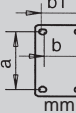
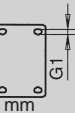
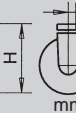

Série GBL

- Jantes en tôle d'acier emboutie zinguée avec roulement à rouleaux
- Chapes pivotantes en tôle d'acier emboutie zinguée
- Double rangée de billes avec joint

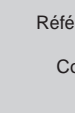
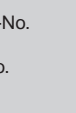

- Rims in pressed steel zinc-plated with roller bearing
- Pressed steel swivel fork zinc plated
- Double ball race, sealed in the swivel head

 D mm	 T mm	 d mm	 T1 mm	 kg	 kg		Référence-No. Code-No.	No. d'identification Identity-No
200	50	20	60	205	1,79		GB 200/ 50/ 4 R	136594
250	60	25	75	295	3,45		GB 250/ 60/ 5 R	100494
280	70	25	85	400	5,00		GBR 280/ 70/ 5 R	281000
400	75	25	75	475	9,90		GB 400/ 75/ 5 R	100500

 D mm x mm	 T mm	 A mm	 b1 mm	 a mm	 b mm	 G1 mm	 H mm	 F mm	 kg	 kg		Référence-No. Code-No.	No. d'identification Identity-No
--	---	---	--	---	---	---	---	---	--	--	--	---------------------------	-------------------------------------



Roulettes Pivotantes

Swivel Castors

200	50	135 x 110	105 x $\frac{75}{80}$	11	235	54	205	2,07		GB L 4/200/50 R	120190
250	60	175 x 175	140 x 140	14,5	290	70	295	7,00		GB L 6/250/60 R	120194
280	70	200 x 160	160 x 120	14	320	72	400	8,40		GBR L 7/280/70 R	120198

Roulettes Fixes

Fixed Castors

200	50	135 x 110	105 x $\frac{75}{80}$	11	235	-	205	2,78		GB B 4/200-50 R	120218
250	60	230 x 125	190 x 75	14,5	290	-	295	5,77		GB B 6/250-60 R	120224
280	70	195 x 160	160 x 120	14	320	-	400	7,30		GBR B 7/280/70 R	120226

Roues charges lourdes à bandage Polyuréthane
75°shore A : Type TG / 92°shore A : Type PG
Vulkollan : Type VG

Heavy duty wheels with Polyurethane tyre
75°shore A : Type TG / 92°shore A : Type PG
Vulkollan : Type VG



Série TG

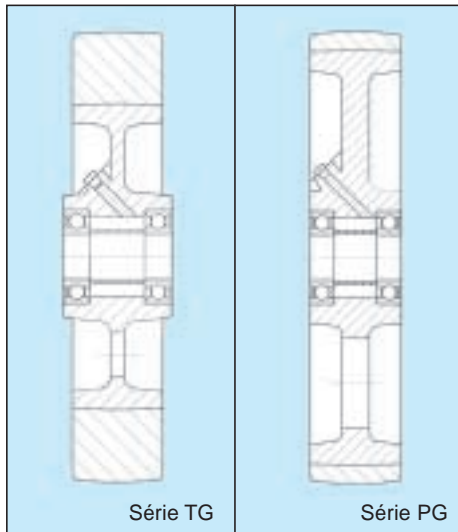

Série TG





















Série PG



Série PG/VG

- Jante en fonte
- Moyeu à roulements à billes

- Cast iron centre
- With precision ball bearings

 D	 T		 d	 T1					Référence-No. Code-No.	No. d'identification Identity-No
mm x mm	mm	mm	mm	mm	mm	kg	kg			
250	80	175	25	85	85	950	10,50		TG 250/ 80/ 5 K	125288
250	80	175	30	85	85	950	10,50		TG 250/ 80/ 6 K	143539
300	75	225	30	75	75	1250	15,50		TG 300/ 75/ 6 K	143540
200	50	170	25	60	60	1000	4,70		PG 200/ 50/ 5 K	107009
250	75	225	30	75	75	1700	9,90		PG 250/ 75/ 6 K	107007
300	75	275	30	85	85	2000	15,50		PG 300/ 75/ 6 K	104790
300	100	225	40	120	120	2500	14,00		PG 300/100/ 8 K	155334
360	75	310	40	90	90	2200	15,00		PG 360/ 75/ 8 K	155337
400	100	310	40	120	120	3100	20,00		PG 400/100/ 8 K	155339
400	125	315	35	140	140	4000	28,50		VG 400/125/ 7 K	155340
425	150	315	45	160	160	4900	30,50		VG 425/150/ 9 K	155341

Roulettes pivotantes inversées pour convoyeurs

Inverted swivel castors for conveyor

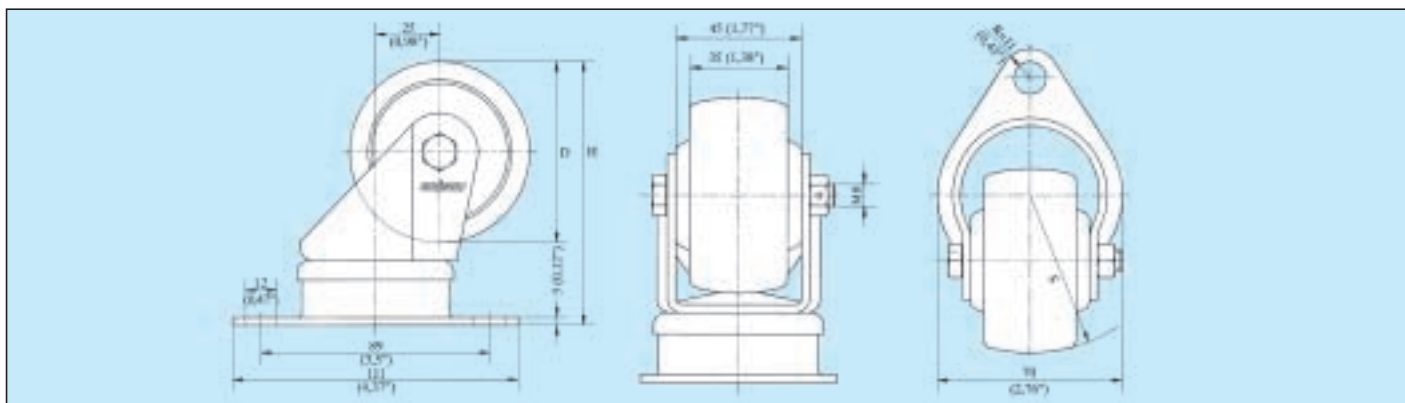

Dimensions mm (inch)			Charge unitaire Load capacity kg (lbs)	Designation	Avec Protège-pieds With toe guard
D	H	S			
58 (2.28")	96 (3.78")	54 (2.13")	200 (450)	JBPN 058-CC1/A	JBPN 058-CC1/AT 12,7
70 (2.76")	102 (4.02")	60 (2.36")	200 (450)	JBPN 070-CC1/A	JPBN 070-CC1/AT 12,7

Couronnes à billes

Turn tables

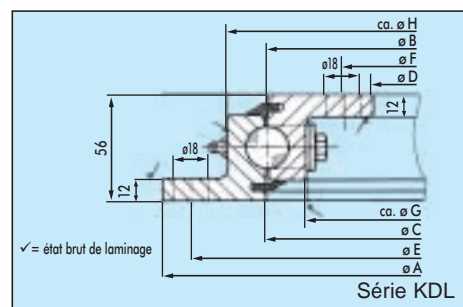
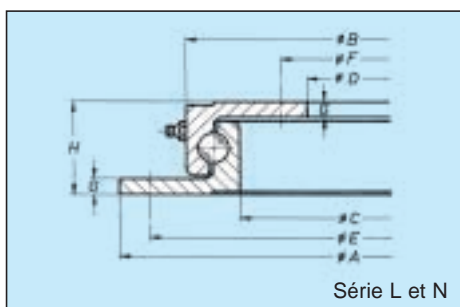

Type	A mm	B mm	C mm	D mm	E mm	F mm	G mm	H mm	Charge ax./L	Réf. Miloco
400 L	400	342	292	230	375	260	8	45	0,75	07 - 000 - 0001
500 L	500	442	392	330	475	360	8	45	0,90	07 - 000 - 0002
650 L	650	592	542	480	625	510	8	45	1,50	07 - 000 - 0003
750 L	750	692	642	580	725	610	8	45	1,80	07 - 000 - 0004
850 L	850	792	742	680	825	710	8	45	2,50	07 - 000 - 0005
950 L	950	892	842	780	925	810	8	45	3,00	07 - 000 - 0006
1050 L	1050	992	942	880	1025	910	8	45	3,50	07 - 000 - 0007
500 N	500	437	384	315	475	340	8	52	1,80	07 - 000 - 0008
650 N	650	587	534	465	625	490	8	52	2,50	07 - 000 - 0009
750 N	750	687	634	565	725	590	8	52	3,00	07 - 000 - 0010
850 N	850	787	734	665	825	690	8	52	3,50	07 - 000 - 0011
950 N	950	887	834	765	925	790	8	52	4,00	07 - 000 - 0012
1050 N	1050	987	934	865	1025	890	8	52	4,50	07 - 000 - 0013
KDL 900-1	520	409	412	302	490	332	371	451	40	07 - 000 - 0030
KDL 900-2	650	539	542	432	620	462	501	581	80	07 - 000 - 0031
KDL 900-3	750	639	642	532	720	562	601	681	120	07 - 000 - 0032
KDL 900-4	850	739	742	632	820	662	701	781	150	07 - 000 - 0033
KDL 900-5	950	839	842	732	920	762	801	881	180	07 - 000 - 0034
KDL 900-6	1050	939	942	832	1020	862	901	981	210	07 - 000 - 0035
KDL 900-7	1200	1089	1092	982	1170	1012	1051	1131	250	07 - 000 - 0036

Pneumatiques industrie diagonaux
Type IC10 / IC12
Pneus pleins souples CSE
Bandages Elastic sur tresse métallique



Pneumatique Type IC 12



Pneu Type SC 10



Bandage Type Elastic

Pneu / Tyre	D T mm x mm	Ply	bar	mm	kg	kg	Profil	No. d'identification Identity-No
-------------	-------------------	-----	-----	----	----	----	--------	-------------------------------------

Pneumatiques industrie diagonaux avec chambres

3.00 x 4	260 x 85	4	6,75	2.10 - 4	255	1,09	IC 10	P 02 - 010 - 0001
4.00 x 4	312 x 116	6	8,00	2.50 C4	535	2,19	IC 10	P 02 - 010 - 0002
4.00 x 8	414 x 120	6	8,00	3.00 D8	780	2,78	IC 10	P 02 - 010 - 0003
4.00 x 8	414 x 120	10	10,00	3.00 D8	950	3,05	IC 10	P 02 - 010 - 0004
5.00 x 8	476 x 143	8	8,25	3.00 D8	1235	5,19	IC 10	P 02 - 010 - 0005
18 x 7 x 8	471 x 187	16	10,00	4.33 R8	2145	7,18	IC 12	P 02 - 010 - 0006

Pneus Pleins Souples - CSE

3.00 x 4	260 x 85	-	-	2.10 - 4	260	3,82	MIL	P 03 - 010 - 0003
4.00 x 4	312 x 116	-	-	2.50 - C4	535	6,41	SC 10	P 03 - 010 - 0004
4.00 x 8	414 x 120	-	-	3.00 - D8	950	10,46	SC 10	P 03 - 010 - 0005
5.00 x 8	476 x 143	-	-	3.00 - D8	1415	16,02	SC 10	P 03 - 010 - 0006
18 x 7 x 8	471 x 187	-	-	4.33 -R8	2145	19,93	SC 10	P 03 - 010 - 0001

Bandages Elastic - Tresse métallique

250 x 80 x 170	250 x 80	-	-	170	675	2,31	lisse	P 04 - 010 - 0001
265 x 160 x 160	265 x 160	-	-	160	1150	6,04	lisse	P 04 - 010 - 0002
300 x 75 x 220	300 x 75	-	-	220	750	2,57	lisse	P 04 - 010 - 0003
300 x 85 x 170	300 x 85	-	-	170	800	4,02	lisse	P 04 - 010 - 0004
310 x 120 x 220	310 x 120	-	-	220	1050	5,08	lisse	P 04 - 010 - 0005
405 x 130 x 305	405 x 130	-	-	305	1500	7,88	lisse	P 04 - 010 - 0006
425 x 150 x 305	425 x 150	-	-	305	1800	11,08	lisse	P 04 - 010 - 0007



**Roues à pneumatique
avec jante en tôle d'acier
Type GBL**

**Pneumatic tyred wheels
with steel RIM
Type GBL**



Série GBL

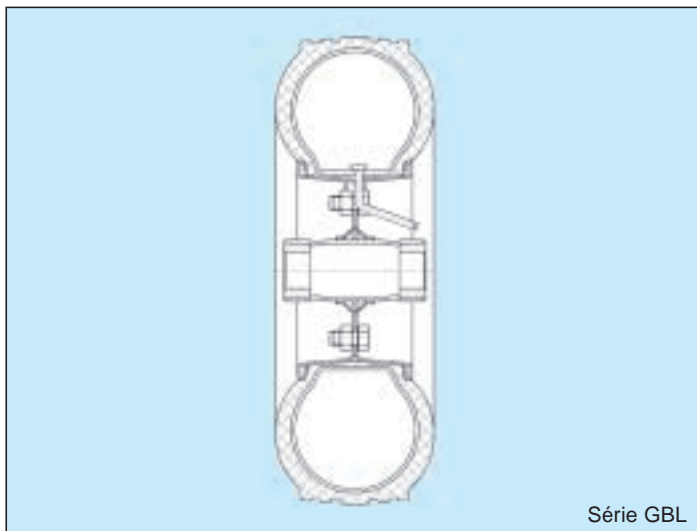

Série GBL

- Jantes en deux parts boulonnées en acier embouti
Peinture gris laqué
- Moyeu à roulements à billes
- Avec cache-moyeu

- Two parts bolted steel disc wheel centers
Grey color
- With precision ball bearings
- With hub cap

Pneu / Tyre	mm x mm		Ply	bar	mm	mm	mm	kg	kg		Référence-No. Code-No.	No. d'identification Identity-No
3.00-4	260	85	4	2,5	2.10-4	20	75	210	1,68		GBL 260/4 K	100541
4.00-4	312	116	6	6,0	2.50-4	25	75	350	2,42		GBL 44E/5 K	F08777
4.00-8	414	120	6	7,0	3.00 D8	25	100	780	6,34		GBL 48E/5 K	508475
4.00-8	414	120	6	7,0	3.00 D8	30	100	780	6,24		GBL 48E/6 K	100553
4.00-8	414	120	6	7,0	3.00 D8	35	68/80	780	6,50		GBL 48E/7 K RA □	F08023
5.00-8	476	143	8	9,0	3.00 D8	25	100	1200	7,96		GBL 58E/5 K	F08778
5.00-8	476	143	8	9,0	3.00 D8	30	100	1200	8,01		GBL 58E/6 K	100554
5.00-8	476	143	8	9,0	3.00 D8	35	68/80	1200	8,40		GBL 58E/7 K RA □	F09139
18x7-8	471	187	14	9,0	4.33 R8	30	120	1850	17,27		GBL 18.7E/6 K	F08473

**Roues à pneu plein caoutchouc
super-élastique
avec jante en tôle d'acier
Type SEB**

*Super elastic cushion tyres wheels
with steel RIM
Type SEB*





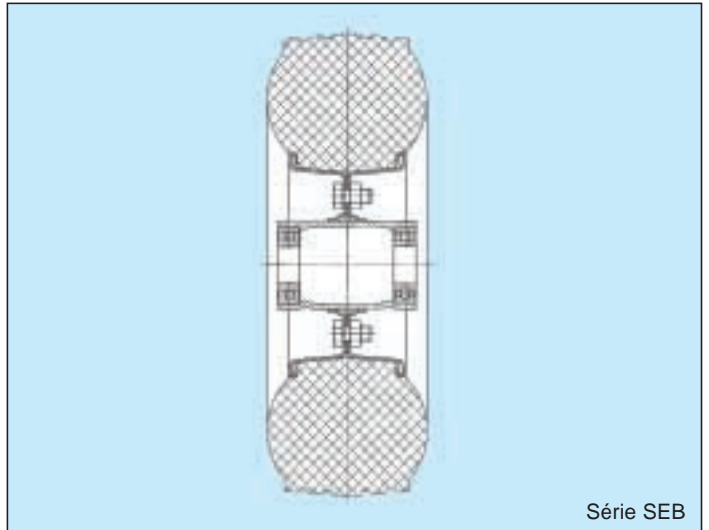







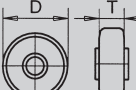





Série SEB



Série SEB

- Jantes en deux parts boulonnées en acier embouti
Peinture gris laqué
- Moyeu à roulements à billes
- ★ Avec cache-moyeu

- *Two parts bolted steel disc wheel centers
Grey color*
- *With precision ball bearings*
- ★ *With hub cap*

 Pneu / Tyre	 mm x mm	 mm	 mm	 mm	 kg	 kg		Référence-No. Code-No.	No. d'identification Identity-No
3.00-4	260 85	2.10-4	20	75	260	4,66		SEB 34/87/4 K	124335
4.00-4	312 116	2.50-4	25	75	535	7,82		SEB 44/116/5 K	124336
4.00-8	414 120	3.00 D8	25	100	950	14,20		SEB 48/121/5 K	124337
4.00-8	414 120	3.00 D8	30	100	950	14,11		SEB 48/121/6 K	F07952
4.00-8	414 120	3.00 D8	35	68/80	950	14,50		SEB 48/121/7K RA ★	F07938
5.00-8	476 143	3.00 D8	25	100	1415	19,80		SEB 58/143/5 K	F08474
5.00-8	476 143	3.00 D8	30	100	1415	19,84		SEB 58/143/6 K	124338
5.00-8	476 143	3.00 D8	35	68/80	1415	20,20		SEB 58/143/7 K RA ★	F06886
18x7-8	471 187	4.33 R8	30	120	2145	27,74		SEB 18.7/187/6 K	F08779





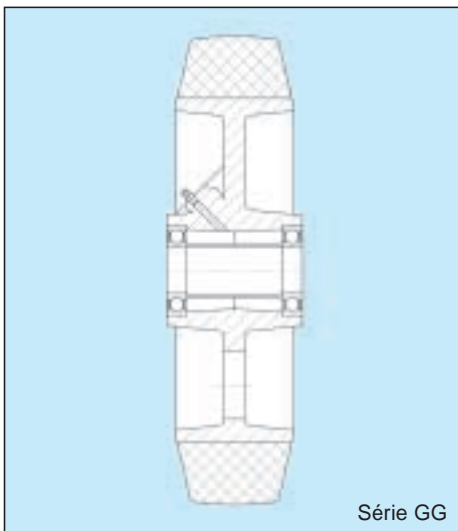









Roues à bandage caoutchouc élastique pressé sur jantes Type GG

Wheels with press-on solid elastic rubber tyres on rims Type GG



- Jantes en fonte
- Bandages caoutchouc élastique avec armatures métalliques montés à la presse sur les jantes
- Moyeu à billes de précision - avec graisseur

- Cast iron rims
- Press-on solid elastic rubber tyres with wire mesh base
- Hub with precision ball bearings and grease nipple

D		T		d	T1				Référence-No.	No. d'identification
mm	x mm	mm	mm	mm	mm	mm	kg	kg	Code-No.	Identity-No
200	50	140	25	60	60	350	4,11		GG 200/ 50/ 5 K	109049
250	50	190	25	60	60	450	6,33		GG 250/ 50/ 5 K	109054
250	80	170	25	85	85	675	9,97		GG 250/ 80/ 5 K	109058
250	80	170	30	85	85	675	10,00		GG 250/ 80/ 6 K	109075
300	75	220	30	85	85	750	11,67		GG 300/ 75/ 6 K	104762
300	85	170	30	90	90	800	10,75		GG 300/ 85/ 6 K	155346
300	85	170	35	90	90	800	10,65		GG 300/ 85/ 7 K	155347
360	85	270	35	90	90	1050	12,50		GG 360/ 85/ 7 K	155344
400	75	305	35	90	90	1000	13,50		GG 400/ 75/ 7 K	155350
Série LARGE										
265	160	160	40	170	165	1150	19,50		GG 265/160/ 8 K	144559
310	120	220	40	120	100	1050	19,70		GG 310/120/ 8 K	145041
405	130	305	40	140	140	1500	38,00		GG 405/130/ 8 K	155351
405	260	305	60	150	150	3000	70,00		GS 405/260/12 K □	151161
415	100	305	40	120	120	1250	30,00		GG 415/100/ 8 K	155353
425	150	305	40	160	160	1800	41,00		GG 425/150/ 8 K	155354

□ GS - Jante mécano-soudée / steel welded rim

**Roues à bandage caoutchouc élastique
moulé sur jantes :**
a c i e r / a l u m i n i u m / f o n t e
Type DB / Type DEN / Type GG

*Wheels with vulcanised elastic rubber tyres
on rims :*
welded steel / aluminium / castiron
Type DB / Type DEN / Type GG



Série DB

















Série DEN
Série DE



Série GG

- Jantes monobloc
- Moyeu à roulements à billes
- avec cache-moyeu

- One part rim
- With precision ball bearings
- with hub cap

D		T	d	T1					Référence-No.	No. d'identification
mm	x mm	mm	mm	mm	mm	kg	kg		Code-No.	Identity-No
200	50	140	20	60	60	420	1,69		DE 200/ 50/4 K	100826
200	50	155	20	60	60	420	3,00		DB 200/ 50/4 K	163876
200	80	155	20	90	90	600	3,30		DB 200/ 80/4 K	163879
250	50	170	25	60	60	500	2,46		DE 250/ 50/5 K	100830
250	80	190	25	90	90	750	4,70		DB 250/ 80/5 K	163881
300	60	225	30	60	60	600	4,26		DEN 300/ 60/6 K	F05726
300	75	225	30	85	85	750	11,63		GG 300/ 75/6 K - S	167314
300	75	225	35	85	85	750	11,50		GG 300/ 75/7 K - S	158428
300	80	170	30	90	90	800	10,50		GGN 300/ 80/6 K	F05872
300	90	210	35	90	88	900	13,40		GG 300/ 90/7 K - S	143704
400	75	310	35	70	60	1000	13,50		GG 400/ 75/7 K RA □	171543
Série LARGE										
265	160	170	40	170	165	1150	18,86		GG 265/160/8 K - S	167316
267	178	175	40	170	165	1315	20,00		GG 267/178/8 K - S	167979
310	120	225	40	120	100	1050	19,71		GG 310/120/8 K - S	143705
415	100	310	40	120	105	1250	17,00		GG 415/100/8 K RA □	165169



Roues à pneumatique avec jante en aluminium Type GBE / SEE

Pneumatic tyred wheels with aluminium rim Type GBE / SEE



Série GBE



Série GBE- 3B



Série SEE

- Jantes en deux parts boulonnées (sauf GBE- 3B) en aluminium
- Moyeu à roulements à billes

- Two parts bolted aluminium disc wheel centers
- With precision ball bearings

Pneu / Tyre	D	T	Ply	bar	mm	d	T1	kg	kg		Référence-No. Code-No.	No. d'identification Identity-No
-------------	---	---	-----	-----	----	---	----	----	----	--	---------------------------	-------------------------------------

Gonflables - GBE

4.00-8	414	120	6	7,0	3.00 D8	30	90	780	4,27		GBE 48E/6 K - 3 B	F07963
4.00-8	414	120	6	7,0	3.00 D8	30	90	780	6,49		GBE 48E/6 K	F08793
4.00-8	414	120	10	10,0	3.00 D8	30	90	950	7,30		GBE 48E/6 K - 10 PR	F03474
5.00-8	476	143	8	9,0	3.00 D8	30	90	1200	8,11		GBE 58E/6 K	F08794
18x7-8	471	187	14	9,0	4.33 R8	40	120	1850	16,72		GBE 18.7E/8 K	F08795

Pneus Pleins - SEE

4.00-8	414	120	-	-	3.00 D8	30	90	950	14,32		SEE 48E/6 K	F08796
5.00-8	476	143	-	-	3.00 D8	30	90	1415	19,95		SEE 58E/6 K	F08797
18x7-8	471	187	-	-	4.33 R8	40	120	2145	27,19		SEE 18.7E/8 K	F08798

Roues à pneumatique avec jante en aluminium Type GBE / SEE

Pneumatic tyred wheels with aluminium rim Type GBE / SEE

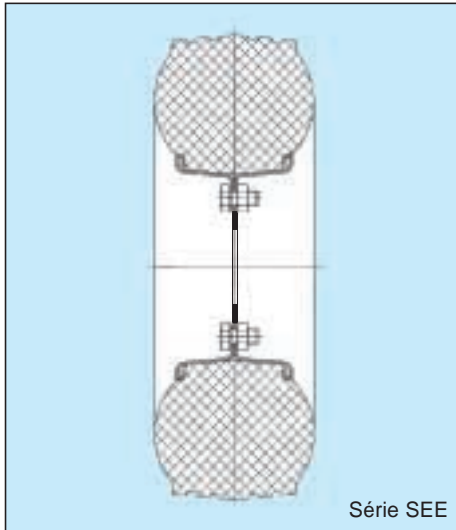

- Jantes en deux parts boulonnées en aluminium
- Sans moyeu, fixation par trous

- Two parts bolted aluminium disc wheel centers
- Without hub, fixing by holes

Pneu / Tyre	D	T	Ply	bar	mm	Nbr. Trous / Holes	d	mm	kg	kg	Référence-No. Code-No.	No. d'identification Identity-No
-------------	---	---	-----	-----	----	--------------------	---	----	----	----	---------------------------	-------------------------------------

Gonflables - GBE

4.00-8	414	120	6	7,0	3.00 D8	4	85	130	780	4,79	GBE 48E/4/130/85	F08785
4.00-8	414	120	10	10	3.00 D8	4	85	130	950	5,60	GBE 48E/4/130/85-10PR	F08786
5.00-8	476	143	8	9,0	3.00 D8	4	85	130	1200	6,41	GBE 58E/4/130/85	F08787
18x7-8	471	187	14	9,0	4.33 R8	6	94	124	1850	12,82	GBE 18.7E/6/124/94	F08788

Pneus Pleins - SEE

4.00-8	414	120	-	-	3.00 D8	4	85	130	950	12,64	SEE 48E/4/130/85	F08789
4.00-8	414	120	-	-	3.00 D8	6	80	120	950	12,64	SEE 48E/6/120/80	F08790
5.00-8	476	143	-	-	3.00 D8	4	85	130	1415	18,25	SEE 58E/4/130/85	F08791
18x7-8	471	187	-	-	4.33 R8	6	94	124	2145	23,29	SEE 18.7E/6/124/94	F08792

**Roues à pneumatique
avec jante en tôle d'acier
Type GBL / SEB**

*Pneumatic tyred wheels
with steel RIM
Type GBL / SEB*



Série GBL

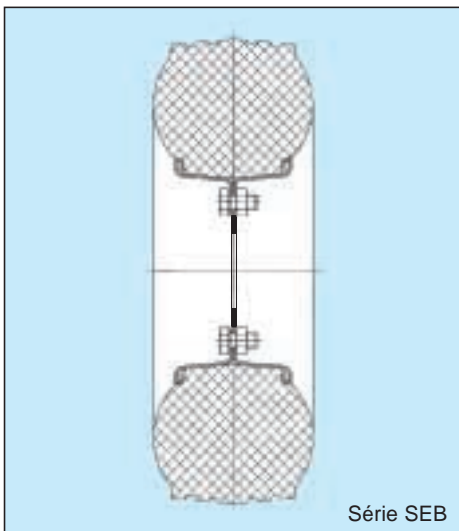









Série SEB



Série SEB

- Jantes en deux parts boulonnées en acier embouti
- Peinture gris laqué
- Sans moyeu, fixation par trous

- *Two parts bolted steel disc wheel centers*
- *Grey color*
- *Without hub, fixing by holes*

Pneu / Tyre	 D	 T	Ply	 bar	 mm	 Nbr. Trous / Holes	 d	 mm	 kg	 kg	Référence-No. Code-No.	No. d'identification Identity-No
-------------	---	---	-----	---	--	--	---	--	--	--	---------------------------	-------------------------------------

Gonflables - GBL

4.00-8	414	120	6	7,0	3.00 D8	4	85	130	780	5,38	GBL	48E/4/130/85	508426
5.00-8	476	143	8	9,0	3.00 D8	4	85	130	1200	6,62	GBL	58E/4/130/85	F08780
18x7-8	471	187	14	9,0	4.33 R8	6	94	124	1850	14,42	GBL	18.7E/6/124/94	F08781

Pneus Pleins - SEB

4.00-8	414	120	-	-	3.00 D8	4	85	130	950	13,29	SEB	48E/4/130/85	F08782
5.00-8	476	143	-	-	3.00 D8	4	85	130	1415	18,94	SEB	58E/4/130/85	F08783
18x7-8	471	187	-	-	4.33 R8	6	94	124	2145	24,89	SEB	18.7E/6/124/94	F08784

**Roulettes pivotantes à grand départ
et à débattement libre
Type GG LAK**

*Swivel castors with large offset
and free clearance
Type GG LAK*















Série GG LAK



Série GG LAK

- Tête de pivotement avec roulement de précision axial et roulement à rouleaux coniques
- Roue à bandage caoutchouc élastique
- Moyeu à roulements à billes

- Swivel head with tapered roller bearing and axial ball bearings
- Wheel with elastic rubber tyre
- With precision ball bearings

																				Référence-No.	No. d'identification
mm x mm		mm		mm		mm		mm		mm		kg		kg		kg		Code-No.	Identity-No		
265	160	255 x 205		210 x 160		18	318	175	1150	56,00		GG LAK 6/265/ 160 K	F08504								
267	178	255 x 205		210 x 160		18	319	175	1315	59,00		GG LAK 6/267/ 178 K	F08799								
250	80+80	255 x 205		210 x 160		18	311	175	1350	52,60		GG LAK 6/250/2x80 K	F08800								



Roulettes
charges
lourdes
spéciales

Special heavy
duty castors