

**Roues et roulettes en résine
phénolique**
Type KPN -40°C +300°C

Wheels and castors in phenolic resin
Type KPN -40°C +300°C

Räder und Rollen aus Phenolharz
Type KPN -40°C +300°C

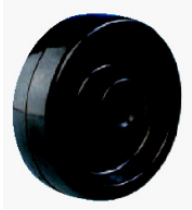

Série KPD...G



Série KPN...K



Série KPD LIC



Série KPN LIC

- Chape en tôle d'acier emboutie Inox AISI 304
- Double rangée de billes
- Axe de roue boulonnée
- Résistantes aux températures de -40°C à +300°C
- Entretoise inox / Teflon

- Pressed steel stainless steel forks AISI 304
- Swivel head with double ball race
- Wheel axle bolted
- Resistant to working temperatures from -40°C to +300°C
- Stainless steel / Teflon bush

- Gabel aus rostfreiem Stahlblech AISI 304
- Schwenklager mit zweifachem Kugelkranz
- Radachse verschraubt
- Hitzebeständig von -40°C bis 300°C
- Rostfreie Rohrzuschnitt mit Teflon

 mm			 mm			 mm			 kg		 Référence-No. Code-No. Artikelbezeichnung		 No. d'identification Identity-No Teile-Nr.	
Roues			Wheels			Räder								
80 x 35			12	40		120			KPD 80/35/1G		420020			
80 x 35			8	41		120			KPN 80/35/0K+CRI/EI		650323			
100 x 35			12	40		150			KPD 100/35/1G		420021			
100 x 35			8	41		150			KPN 100/35/0K + CRI/EI		650324			

 mm				 mm				 mm				 kg		 Référence-No. Code-No. Artikelbezeichnung		 Teile Nr. / Ident-No.	
Roulettes				Castors				Rollen									
80 x 35	95 x 80	80 x 60	9	108	32	120			KPD LIC 01/80/35G EI TEFLON		320046						
			9	108	-	120			KPN LIC 01/80/35K		320047						
100 x 35	95 x 80	80 x 60	9	127	32	150			KPD LIC 02/100/35G EI TEFLON		320048						
			9	127	-	150			KPN LIC 02/100/35K		320049						

Roues et roulettes en résine phénolique
 type KPN - 40°C + 300°C
 en résine renforcée de fibres
 type KPS - 40°C + 300°C

Wheels and castors in phenolic resin
 type KPN - 40°C + 300°C
 in phenolic resin with glass fibre
 type KPS - 40°C + 300°C

Räder und Rollen aus Phenolharz
 Type KPN - 40°C + 300°C
 aus Phenolharz mit Glasfaser
 type KPS - 40°C + 300°C

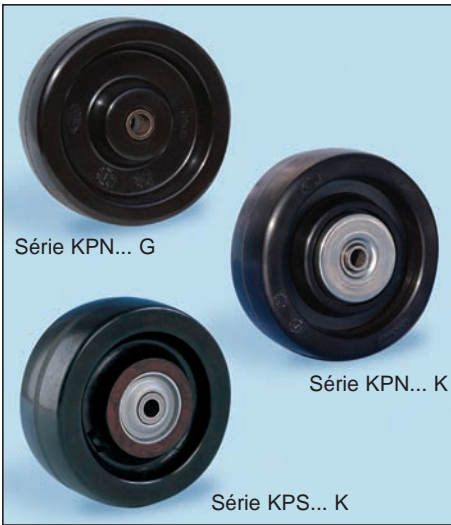

- Chapes en tôle d'acier emboutie Inox AISI 304
- Double rangée de billes
- Axe de roue boulonné
- Résistantes aux températures de - 40°C à + 300°C

- Pressed steel stainless steel forks AISI 304
- Swivel head with double ball race
- Wheel axle bolted
- Resistant to working temperatures from - 40°C to + 300°C

- Gabel aus rostfreiem Stahlblech AISI 304
- Schwenklager mit zweifachem Kugelkranz
- Radachse verschraubt
- Hitzebeständig von - 40°C bis + 300°C

mm x mm		mm	mm	kg		Référence-No. Code-No. Artikelbezeichnung	No. d'identification Identity-No Teile-Nr.				
Roues		Wheels				Räder					
KPN											
80 x 35		10	40	120		KPN 80/35/G AL10 (Bague Bronze)	800028				
80 x 35		8	41	120		KPN 80/ 35/ 0 K + CRI/EI	650323				
100 x 35		10	40	150		KPN 100/35/G AL10 (Bague Bronze)	800029				
100 x 35		8	41	150		KPN 100/ 35/ 0 K + CRI/EI	650324				
KPS... K											
70 x 40		8	45	200		KPS 70/ 40/ 2 K + CR + ENT	F08731				
100 x 40		8	45	200		KPS 100/ 40/ 2 K + CR + ENT	F07825				
mm x mm		mm	mm	mm	mm	mm	kg		Référence-No. Code-No. Artikelbezeichnung	Ident-No./Teile-Nr.	
Roulettes		Castors								Rollen	
KPN											
80 x 35	105x 80	80x 60	9	106	38	120		KPN LI 01/ 80/35 G	300250		
			9	106		120		KPN BI 01/ 80/35 G		300251	
			9	106	38	120		KPN LI 01/ 80/35 K	650325		
			9	106		120		KPN BI 01/ 80/35 K		650326	
			9	108	38	120		KPN LIN 01/ 80/35 K	650327		
			9	108		120		KPN BIN 01/ 80/35 K		650328	
			9	108	40	120		KPN LVIN 01/ 80/35 K	650329		
			9	108		120		KPN BVIN 01/ 80/35 K		650330	
			100 x 35	105x 80	80x 60	9		128	38	150	
9	128	—				150	KPN BI 02/100/35 G		300253		
9	128	38				150	KPN LI 02/100/35 K	650331			
9	128	—				150	KPN BI 02/100/35 K		650332		
9	128	42				150	KPN LIN 02/100/35 K	650333			
9	128	—				150	KPN BIN 02/100/35 K		650334		
9	128	45				150	KPN LVIN 02/100/35 K	650335			
9	128	—				150	KPN BVIN 02/100/35 K		650336		
KPS... K											
70 x 40	105x 80	80x 60	9	113	38	200		KPS LIN 02/ 70/40 K	F08875		
			9	113		200		KPS BIN 02/ 70/40 K		F80113	
100 x 40	105x 80	80x 60	9	128	38	200		KPS LIN 02/100/40 K	F08407		
			9	128		200		KPS BIN 02/100/40 K		F80114	



Roues avec roues en Polyamide chargé fibre de verre type FV
- 40°C + 180°C

Polyamid glassfiber wheels type FV
- 40°C + 180°C

Polyamid aus Glasfiber Rädern
Type FV - 40°C + 180°C



Roues en Polyamide chargé fibre de verre
Roulement facile sur sol lisse
Incassable, même sous charges lourdes
Résistantes à l'eau saline, aux détergents et acides
Résistantes de -40°C à +180°C

- Polyamid wheels with glassfiber
- Easy running on smooth floors
- Unbreakable under high loads
- Highly resistant to saline water, detergents, acids
- Heat resistant to working temperatures from -40°C to +180°C

- Polyamid-Räder mit Glasfiber
- Leichter Lauf bei glatten Böden
- Bruchsicher bei hoher Belastung
- Weitgehend beständig gegen Salzwasser, Laugen und Säuren
- Hitzebeständig von -40°C bis +90°C

					Référence-No. Code-No. Artikelbezeichnung	No. d'identification Identity-No Teile-Nr.
--	--	--	--	--	---	--

Roues			Wheels			Räder	
80 x 30	12	40	100	≡	FV 80/30/1G	700090	
100 x 30	12	40	150	≡	FV 100/30/1G	700025	
125 x 40	12	44	200	≡	FV 125/40/1G	700035	
125 x 40	20	60	200	≡	FV 125/40/4G	700010	
150 x 40	20	60	300	≡	FV 150/40/4G	700049	
160 x 45	20	60	400	≡	FV 160/45/4G	700022	
200 x 50	20	60	400	≡	FV 200/50/4G	700021	

N.B. : Moyeu à rouleaux inox sur demande



Roulettes pivotantes et fixes en Inox avec roues en Polyamide chargé fibre de verre type FV

Stainless steel swivel and fixed castors with Polyamid glassfiber wheels type FV - 40°C + 180°C

Inox Lenkrollen und Bockrollen mit Polyamid aus Glasfaser Rädern Type FV - 40°C + 180°C



Série FV LIC



Série FV LIC FSTF

Roues en Polyamide chargé fibre de verre
Roulement facile sur sol lisse
Incassable, même sous charges lourdes
Résistantes à l'eau saline, aux détergents et acides
Résistantes de -40°C à +180°C

- Polyamid wheels with glassfiber
- Easy running on smooth floors
- Unbreakable under high loads
- Highly resistant to saline water, detergents, acids
- Heat resistant to working temperatures from -40°C to +180°C

- Polyamid-Räder mit Glasfaser
- Leichter Lauf bei glatten Böden
- Bruchsicher bei hoher Belastung
- Weitgehend beständig gegen Salzwasser, Laugen und Säuren
- Hitzebeständig von -40°C bis +90°C

								Référence-No. Code-No. Artikelbezeichnung	Teile Nr. / Ident-No. 	FSTF
--	--	--	--	--	--	--	--	--	----------------------------------	------

Roulettes			Castors				Rollen				
80 x 30	95 x 80	80 x 60	9	108	32	100	≡	FV LIC 01/80/30G	320254	320255	
			9	108	-	100	≡	FV BIC 01/80/30G	320256		
100 x 30	95 x 80	80 x 60	9	127	32	150	≡	FV LIC 02/100/30G	320257	320258	
			9	127	-	150	≡	FV BIC 02/100/30G	320259		
125 x 40	95 x 80	80 x 60	9	155	32	150	≡	FV LLIC 03/125/40G	320260	320261	
			9	155	-	150	≡	FV BBIC 03/125/40G	320262		
125 x 40	135 x 110	105 x 80	11	160	45	200	≡	FV LI 04/125/40G	F06708	F09992	
			11	160	-	200	≡	FV BI 04/125/40G	F06709		
150 x 40	129 x 106	105 x 80	11	192	52	200	≡	FV LIC 1/150/40G	320263	320264	
	150 x 110	105 x 80	11	192	-	200	≡	FV BIC 1/150/40G	320265		
150 x 40	135 x 110	105 x 80	11	190	55	250	≡	FV LI 1/150/40G	300277	---	
	150 x 110	105 x 80	11	190	-	250	≡	FV BI 1/150/40G	300278		
160 x 45	135 x 110	105 x 80	11	195	55	300	≡	FV LI 1/160/45G	300280	F09185	
	150 x 110	105 x 80	11	195	-	300	≡	FV BI 1/160/45G	300281		
200 x 45	129 x 106	105 x 80	11	240	48	200	≡	FV LIC 4/200/45G	320266	320267	
			11	240	-	200	≡	FV BIC 4/200/45G	320268		
200 x 45	135 x 110	105 x 80	11	235	55	300	≡	FV LI 4/200/45G	300283	F06460	
	150 x 110	105 x 80	11	235	-	300	≡	FV BI 4/200/45G	300284		

Roues et roulettes en caoutchouc + Silicone jante aluminium
type SIE - 30°C + 280°C

Wheels and castors in rubber + Silicone aluminium rim
type SIE - 30°C + 280°C

Räder und Rollen aus Vollgummibereifung + Silicone Aluminium Felge
Type SIE - 30°C + 280°C

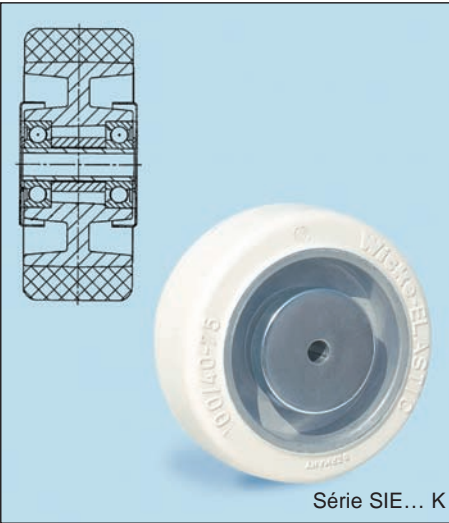

- Chapes en tôle d'acier emboutie Inox AISI 304
- Double rangée de billes
- Axe de roue boulonné
- Résistantes aux températures de - 30°C + 280°C
- Pare-fils zingués, roulements à billes standard

- Pressed steel stainless steel forks AISI 304
- Swivel head with double ball race
- Wheel axle bolted
- Resistant to working temperatures from - 30°C + 280°C
- Zincd threadguards, standard ball bearings

- Gabel aus rostfreiem Stahlblech AISI 304
- Schwenklager mit zweifachem Kugelkranz
- Radachse verschraubt
- Hitzebeständig von - 30°C + 280°C
- Fadenschutz verzinkt, standard Rillen Kugellager

mm x mm	mm	mm	kg		Référence-No. Code-No. Artikelbezeichnung	No. d'identification Identity-No Teile-Nr.
---------	----	----	----	--	---	--

Roues	Wheels	Räder
SIE... K-FAK		
100 x 40	12	40
	80 (1)	H
		SIE 100/40/75-1 K-FAK
		193031

mm x mm	mm	mm	mm	mm	mm	mm	kg		Référence-No. Code-No. Artikelbezeichnung	Ident-No./Teile-Nr.		
---------	----	----	----	----	----	----	----	--	---	---------------------	--	--

100 x 40	105 x 80	80 x 60	9	127	32	80	H	SIE LIC 02/100-40 K-FAK	320044		—
			9	127	—	80	H	SIE BIC 02/100-40 K-FAK		320045	
100 x 40	105x 80	80x 60	9	128	38	80	H	SIE LIN 02/100-40 K-FAK	F11463		—
			9	128	—	80	H	SIE BIN 02/100-40 K-FAK		F11532	
			9	128	45	80	H	SIE LVIN 02/100-40 K-FAK	F11464		
			9	128	—	80	H	SIE BVIN 02/100-40 K-FAK		F11533	—

(1) N.B. : charge unitaire admissible sous température +280°C